

INSTRUCTIONS FOR AUTHORS

The paper has to be sent as Word document, all figures attached, to the e-mail address of the editorial staff. The e-mail message including the attached files shall not exceed 10MB; if this size is exceeded, please send via a web application for transferring large files. For a better control please send us a pdf. version too or a paper copy at a resolution of at least 300dpi.

Please make sure that the text, figures and formulas are legible and the contrast is adequate.

1. Page format

Page format A4 with margins:

- top: 2.5 cm.,
- bottom: 2.5 cm.,
- right: 2.0 cm.,
- left: 1.0 cm.,
- Gutter: 0 cm.,
- Header: 1.25 cm.,
- Footer: 1.25 cm.

Two equal columns, 6 mm spacing.

2. Text

Title - Arial 18pt bold, centred on the page width, single line spacing, 12 pt spacing after and it will not exceed two lines

Please write in a single column.

Authors – Arial 10 pt., regular, centred on the page width. The surname of the author shall be written with full capital letters (i.e. MARINESCU Adrian).

If there are more authors, insert commas between their names (;). If the authors have different affiliations use numbers (1, 2 etc.) as superscripts.

Please write in a single column.

Authors' affiliation – Arial 10 pt., regular, centred on the width of the page. Capitalize initial letters. Between authors and affiliation leave a free line. When there are at least two affiliations, before the affiliation's name write the superscript's number used for authors' name; institutions are separated by commas.

Please write in a single column.

First Author's e-mail address – Arial 10 pt., italic, centred on the width of the page.

Abstract – Times New Roman 10 pt. regular, justify aligned, single spacing. The abstract will have maximum 10 lines and should give general overview of the most relevant aspects of the paper.

Please write in a single column.

Keywords – Times New Roman 10 pt. regular, justify aligned, single spacing. Maximum 5 keywords (or group of words).

Chapter text/ – Arial 11 pt., bold, left aligned, 10 pt. spacing before and 6 pt. spacing after. Arabic numbers shall be used followed by dot and a blank space.

Subchapter 1 text – Times New Roman 10 pt, bold + italic, left aligned, 6 pt. spacing before and after. The number of subchapters includes the number of the main chapter, dot, number of subchapter, dot and a blank space.

Subchapter 2 text – Times New Roman 10 pt, regular + italic, left aligned, 3 pt. spacing before and after. The number of subchapters includes the number of the main chapter, dot, number of subchapter, dot and a blank space.

Paper body text - Times New Roman 10 pt, regular, fully justified, single spacing. Paragraphs indented at 4mm.

Illustrations - Illustrations (figures) should be in greyscale, minimum resolution 300 dpi, jpg or tiff format and corresponding contrast.

Illustrations should be placed as close as possible to their first mentioning in text.

An illustration larger than the column's width should be placed on two columns, at the end of the page, preferably.

Explanations to the figures should be placed under the figures, should be preceded by „Fig.” followed by blank space, number of the illustration (Arabic numbers), dot and blank space. Times New Roman 9 pt., regular, spacing 3 pt. before and 3 pt. after, centred on the width, single spacing.

In the text, references to figures should be made by writing Figure x at the beginning of sentences and fig. X in the interior of sentences. Texts in the illustrations should be of sufficient size to be legible.

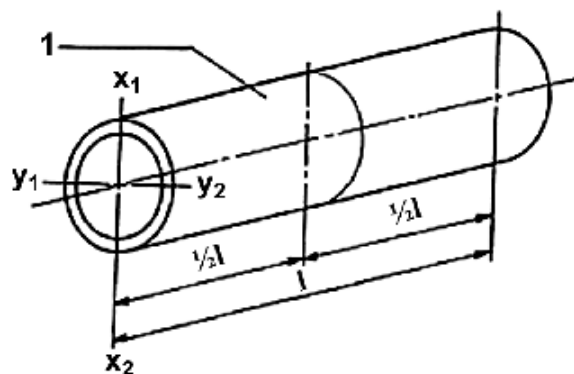

Fig. 1 Test piece for a butt weld (4 test specimens, 1 in each location x_1 , x_2 , y_1 , y_2)

Tables

All tables shall be created using the Table utility provided by Microsoft Word.

Information in the interior of tables shall be written using Times New Roman 9 pt, regular, single spacing.

A table wider than a single column shall be placed on two columns, preferably at the bottom of the page. Tables should be no longer than the page length. Tables on landscape type page can be used, if necessary.

Explanations referring to tables should be placed above the table, inserting the word "Table" followed by a blank space, table number (Arabic numbers), dot and blank space. Times New Roman 9 pt., regular, aligned left, spacing 3 pt. before and 3 pt. after, single spacing.

In the text, references to tables shall be made writing Table x at the beginning of sentences and tab. X in the interior of sentences.

Symbols and acronyms

Use ISO standard symbols and abbreviations. The International System of Units (SI units) is compulsory. Define any acronyms the first time they appear within the text. For documents including more acronyms it is recommended to have a list of definitions at the end of the paper.

Terminology

Because welding is a special processing procedure, the terminology used covers a variety of specific terms for many scientific disciplines. Thus we recommend the usage of ANSI/AWS A3.0-01 Standard Welding Terms and Definitions. Terms not covered by this standard shall be in accordance with the standard recognised for the discipline they belong to.

Equations

Equations should be created using Equation editor from Microsoft Word.

When numbering equations, use Arabic numbers in round parenthesis and align the number to the right.

An example of a one-column equation:

$$\beta = \sum_{n=4}^{22} \frac{\sqrt{s^2 + 22 \sin(\alpha) + \prod_{i=1}^{22} \frac{254}{2} i \sqrt{s - 34^{2 \ln(\alpha - 23)}} - 21 \operatorname{ctg}(i + j \operatorname{tg} \alpha)}}{s^2 - 0,34 + 20,34 \operatorname{tg} \alpha} \quad (1)$$

Acknowledgements

Acknowledgements shall be written just before *References*, or in the interior of the two text columns, not separately from the body text of the paper. The word Acknowledgements shall have the format as a chapter title and no number. Acknowledgements may be addressed to individuals or institutions not mentioned elsewhere in the paper that have made notable contributions to the results presented in the paper.

References

The word *References* shall have the format as the chapter title, no number.

References will be typed with Times New Roman 10 pt, regular, aligned left, single spacing and will contain the number of reference between square brackets, name of the

author followed by their initials, applicable to each author, colon, full paper title (*italic*), name of publication it was edited in, publishing house or institution name, city, year of publication, volume and number of publication (if necessary), group “p” followed by the number of the first and last page of the document, separated by a dash.

All references should be cited in text. In the body text of the document the reference will be cited with Arabic numbers, placed between square parentheses [x]. In case of more than two citations, numbers should be separated by comma and space [x,w,y]. In case of more than two continuously numbered references, the numbers should be separated by a dash [a-g].

Reference titles will be written in the language they were edited in, translation into English is possible if relevant, which may be put between round parentheses, immediately after the original title. The text including non-Latin words will be transliterated according to the international standards.

Examples:

[1] Dilthey U., Ulrico K.: GMA-Brazing of Galvanized and Alloyed Steels, IIW Doc. XII-1630-00, Welding Institute, Aachen University, Germany, 2000.

[2] Faerber M.: Process Gases for Laser Welding, Proceedings of CISFFEL, Toulon, 1998, p. 837-841.

[3] Radaj, D.: Heat effects of welding: temperature field, residual stress, distorsion, Springer-Verlag Berlin Heidelberg, Germany, 1992.

Please note

Full responsibility for the content of the paper rests on the authors. The authors must have taken the necessary steps to obtain permission for using any material that might be protected by copyright.

Statements and opinions contained in published papers are understood to be individual expressions of the authors and not of those of the journal editor.

Reviewers and editors may suggest some changes. Corrections to the paper cannot be undertaken by the editorial staff of the publication. The main author will receive the reviewing and editing notes, by e-mail, at least one month after the paper submission date. The final form of the paper must be sent by e-mail, in two electronic formats: Word and Adobe Acrobat, as attachments to a message not exceeding a total of 10 MB.

Authors should not forget to send information regarding their contact data (address, e-mail, fax etc.)

Checklist

To avoid overlooking important details, the authors are advised to make the checklist supplied with these instructions and suggestions.

- Subject target: Papers should give new facts, new methods, experimental results or important conclusions about modelling, processing, techniques, fabrication, operation, maintenance, safety or related subjects.
- The title will not exceed more than two lines.



Welding and Material Testing

ISSN 1453-0392

Bulletin of the National Research & Development Institute for Welding and Material Testing - ISIM Timișoara

- Headings and Subheadings: Several headings (subheadings, if needed), should be used throughout the text to divide the text into its important, logical parts.
- *Length of the manuscript should not exceed 6 pages for research papers or 5 pages for other presentation types.*
- Photographs: should be clear and exact, with a corresponding contrast. Please do not send poor quality reproductions.
- Avoid using symbols, consecrated names, trademarks, etc.
- Terms and definitions standardized by the American Welding Society (AWS) must be used.